

SECCION TRANSVERSAL 1 - ESTADO ACTUAL

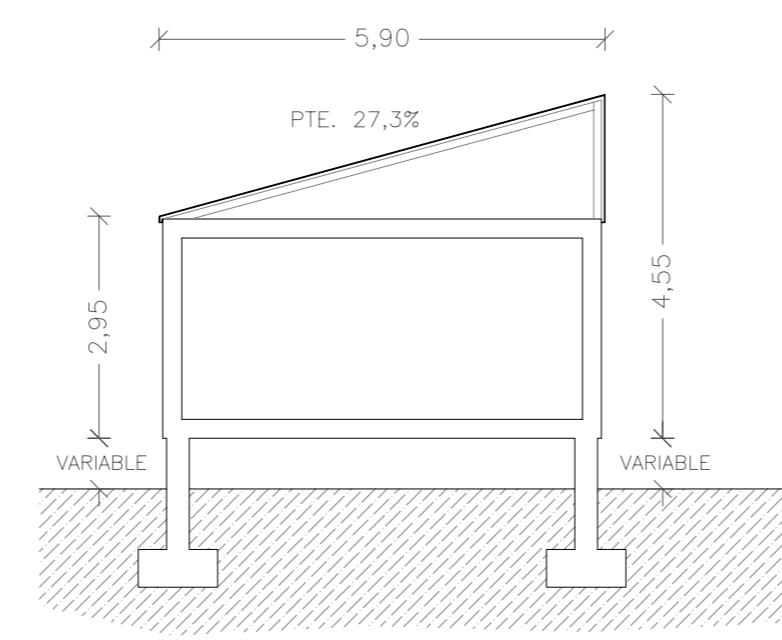

SECCION TRANSVERSAL 2 - ESTADO ACTUAL

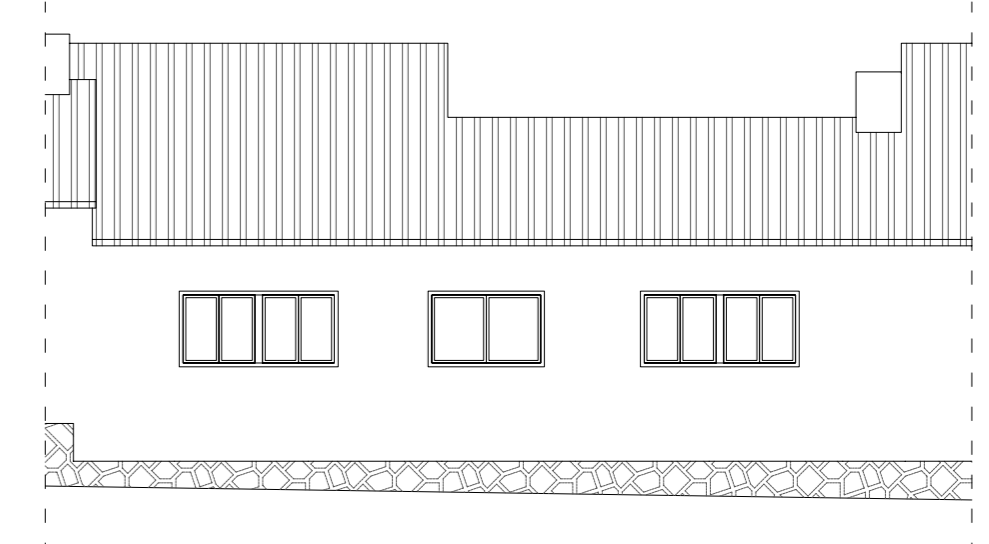

ALINEACIONES Y SUPERFICIES
ESTADO ACTUAL - PLANTA BAJOCUBIERTA

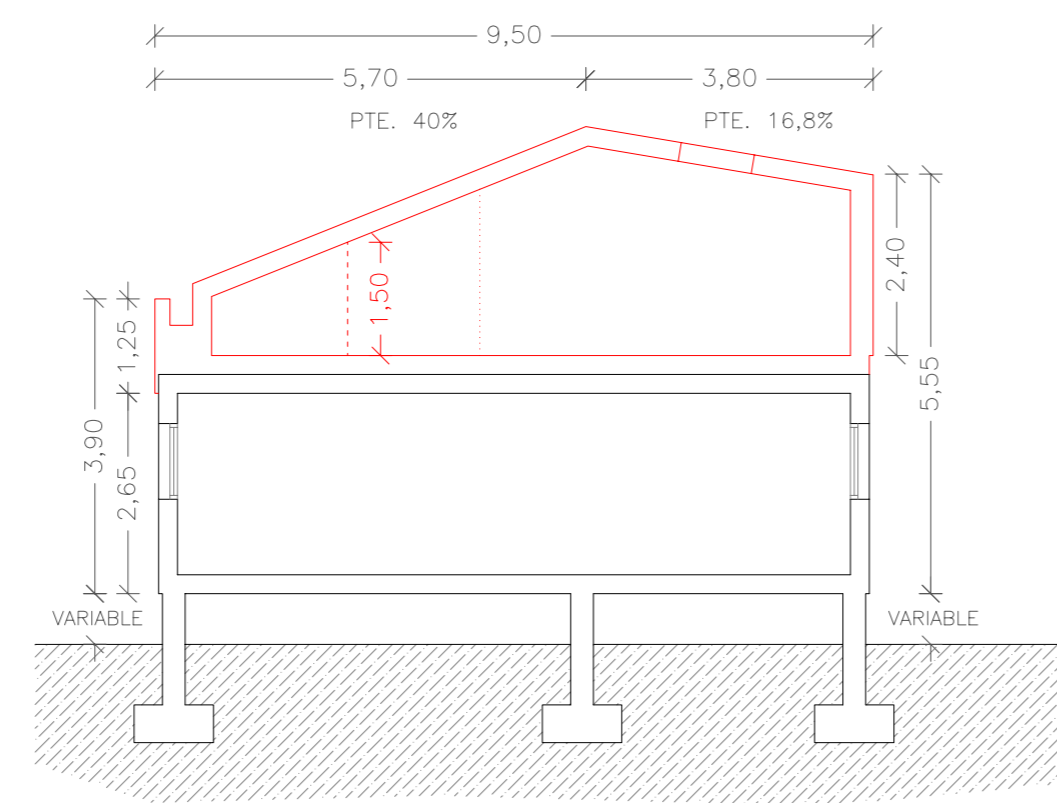
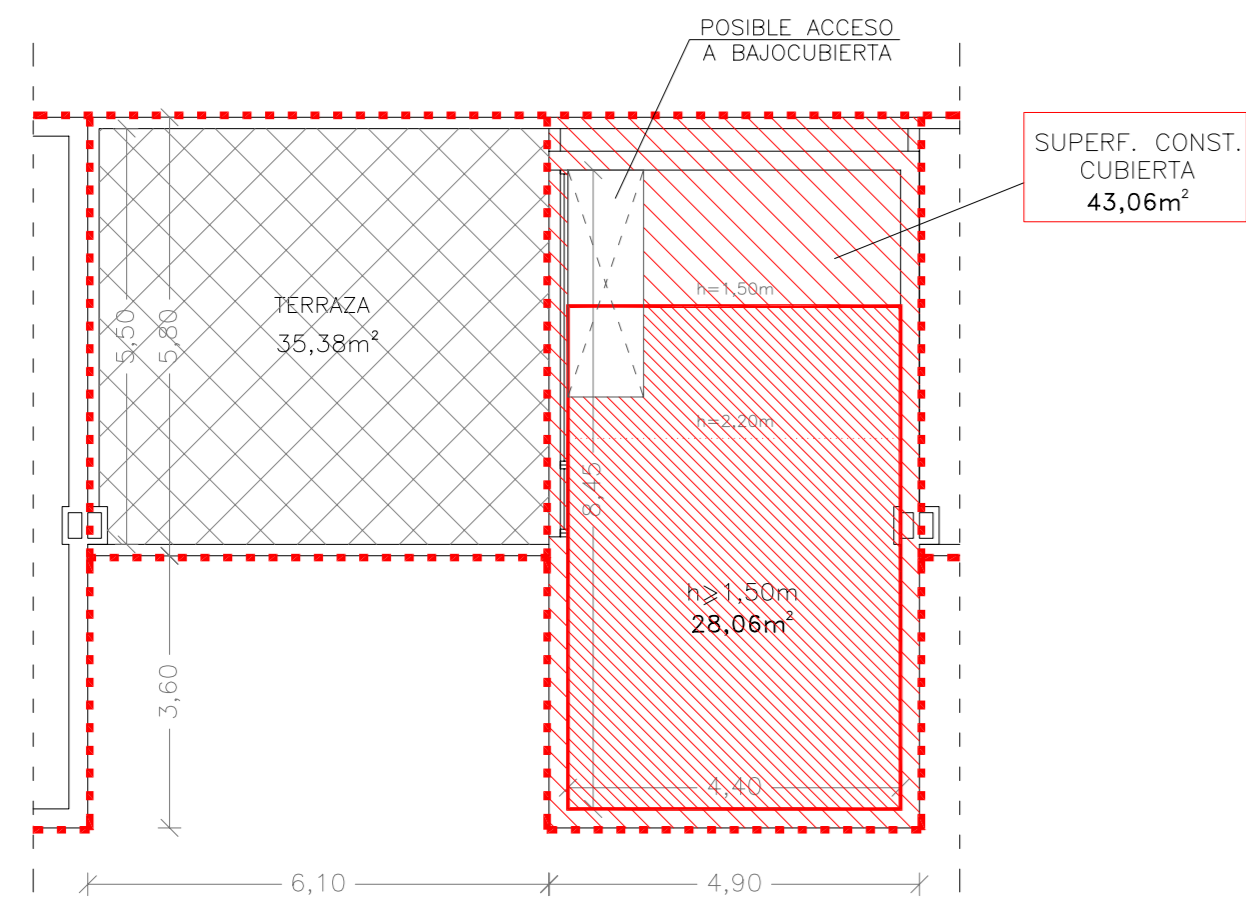

SECCION TRANSVERSAL 1 - ESTADO REFORMADO

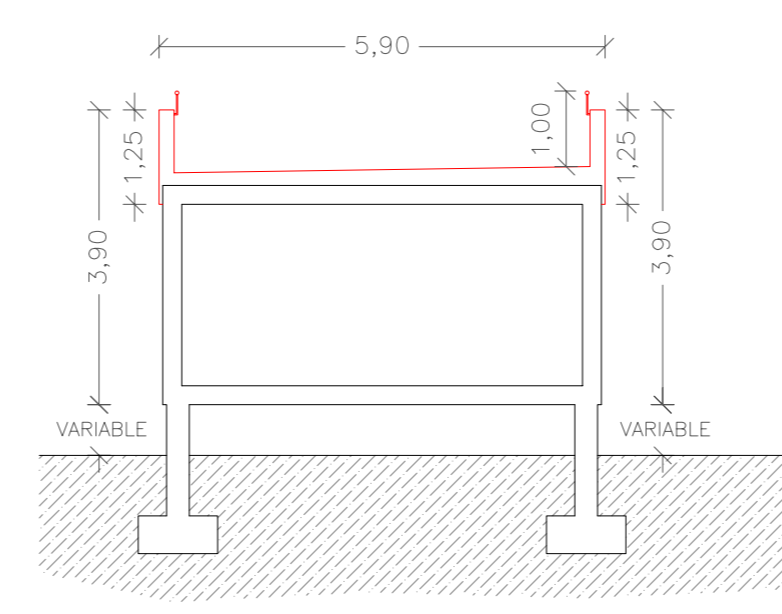

SECCION TRANSVERSAL 2 - ESTADO REFORMADO

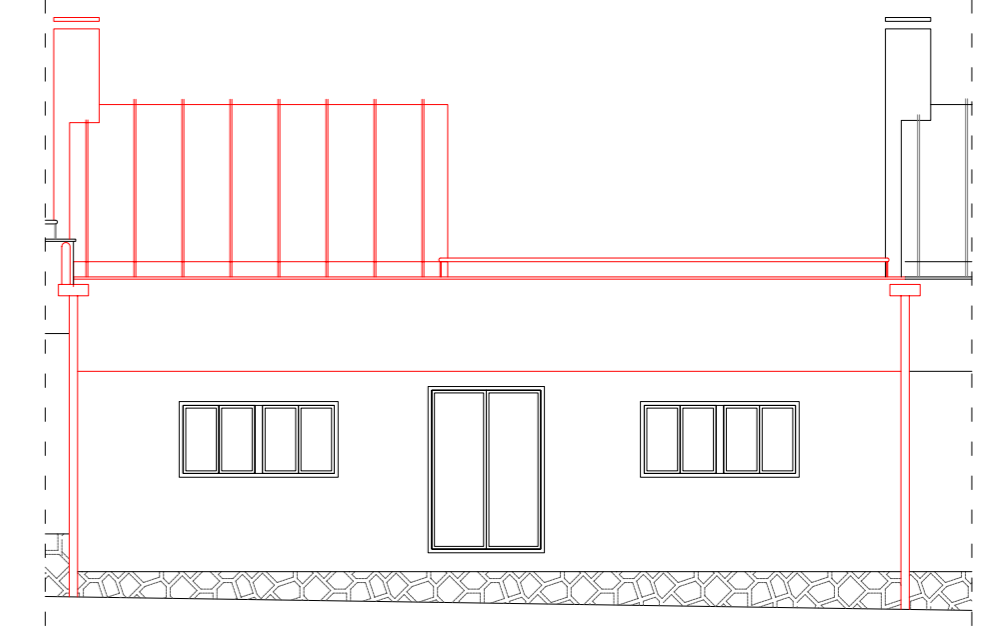
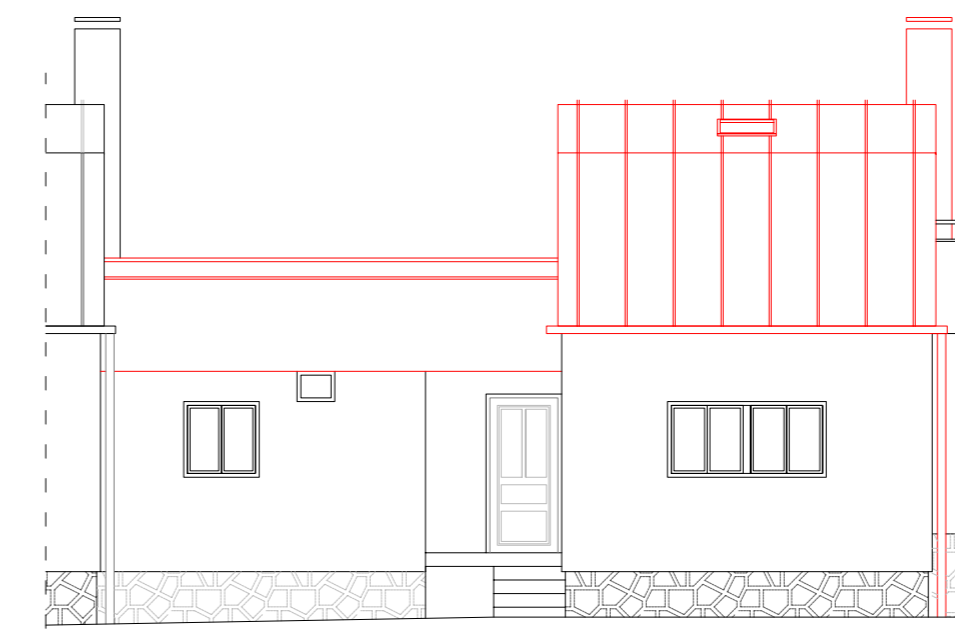

ALINEACIONES Y SUPERFICIES
ESTADO REFORMADO - PLANTA BAJOCUBIERTA

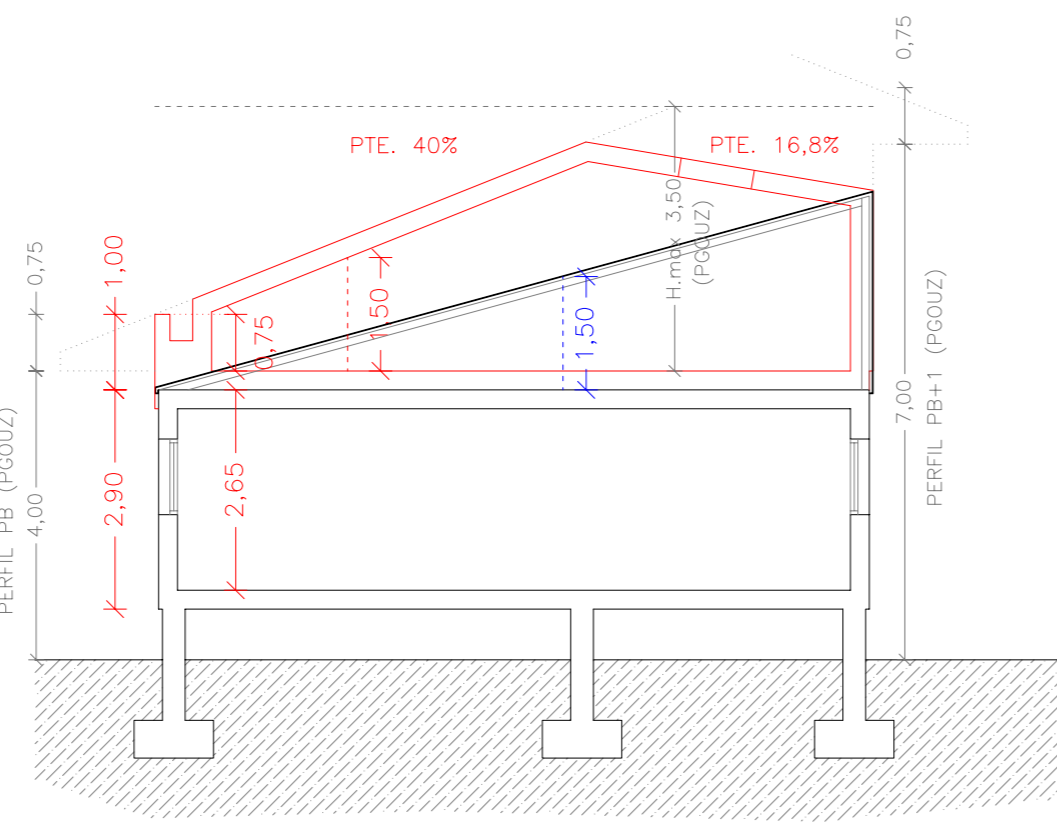
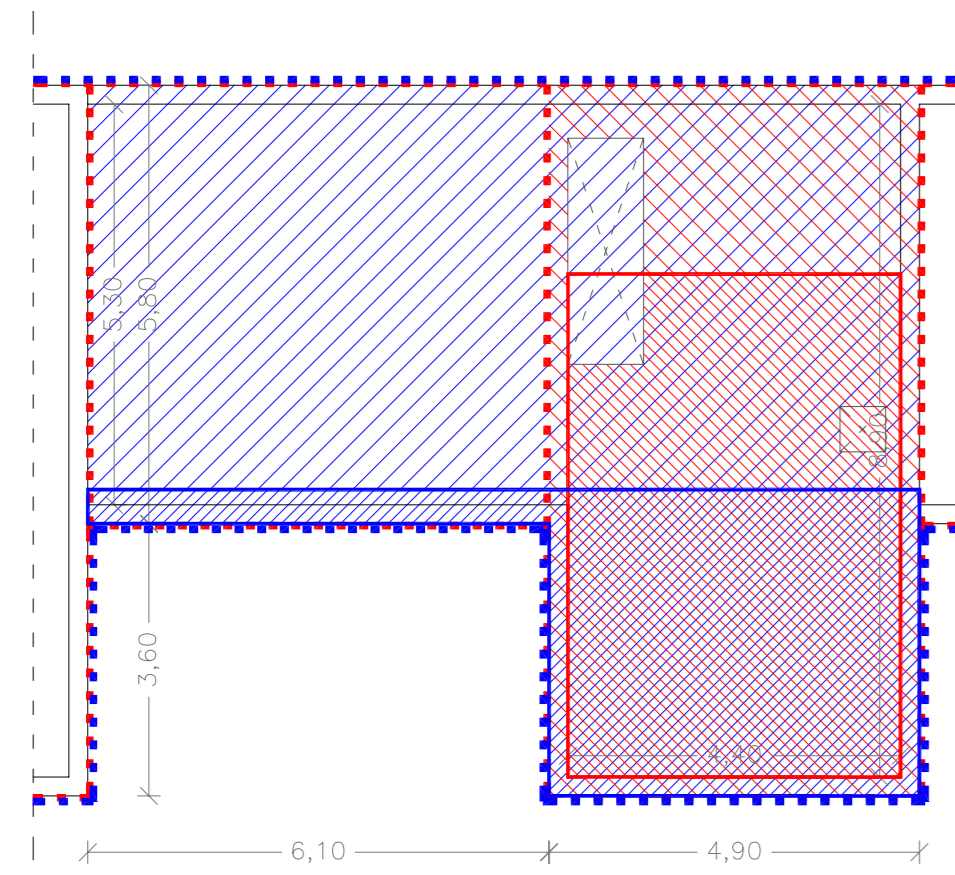

SECCION TRANSVERSAL 1 - SUPERPUESTO

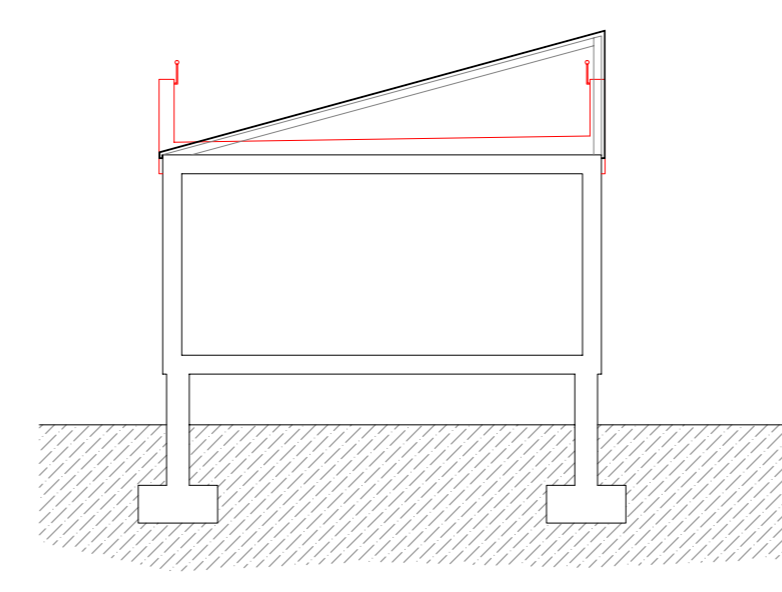

SECCION TRANSVERSAL 2 - SUPERPUESTO

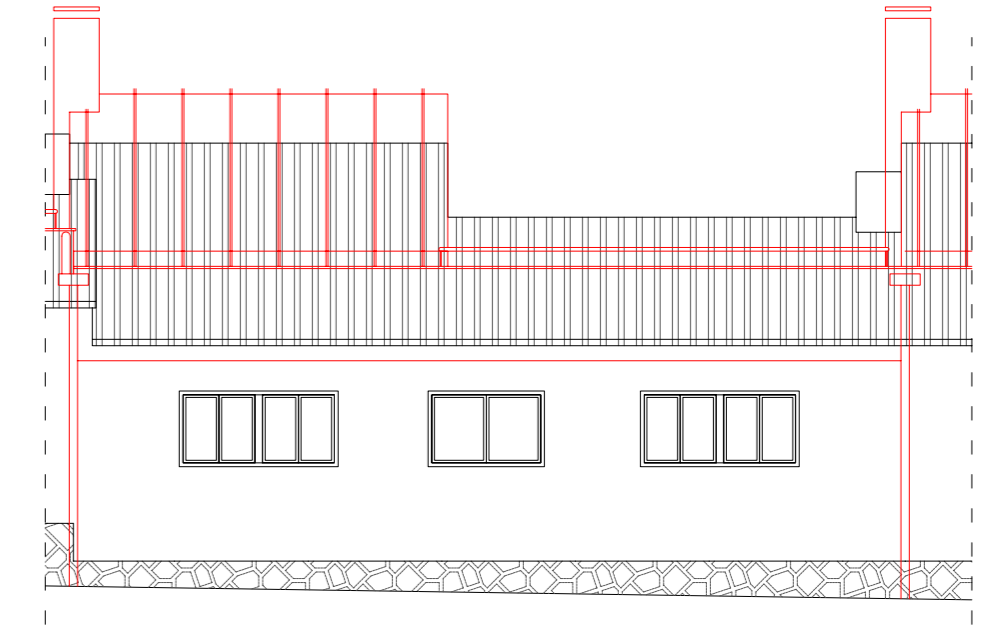
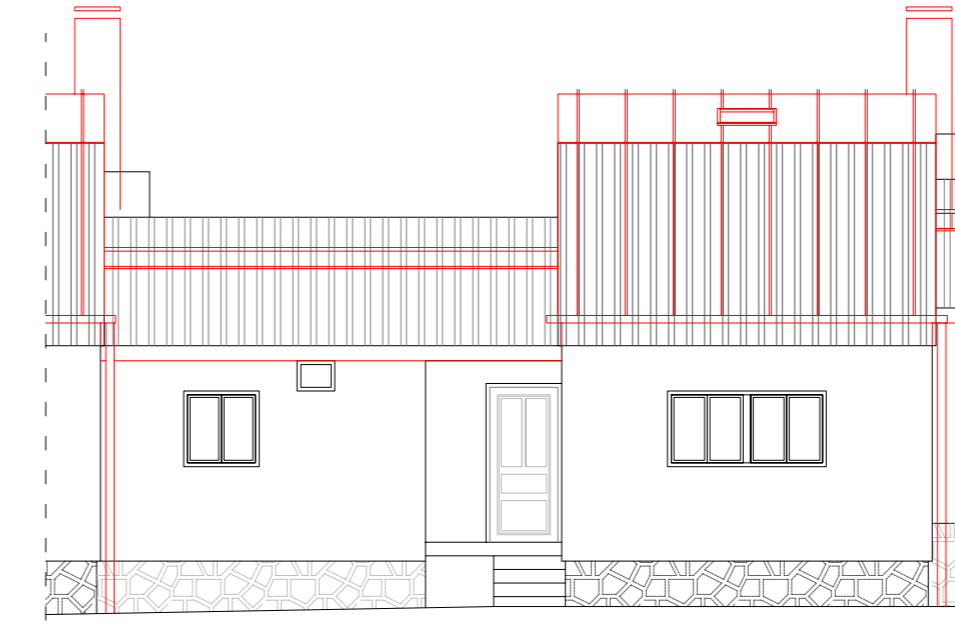

ALINEACIONES Y SUPERFICIES
SUPERPUESTO - PLANTA BAJOCUBIERTA

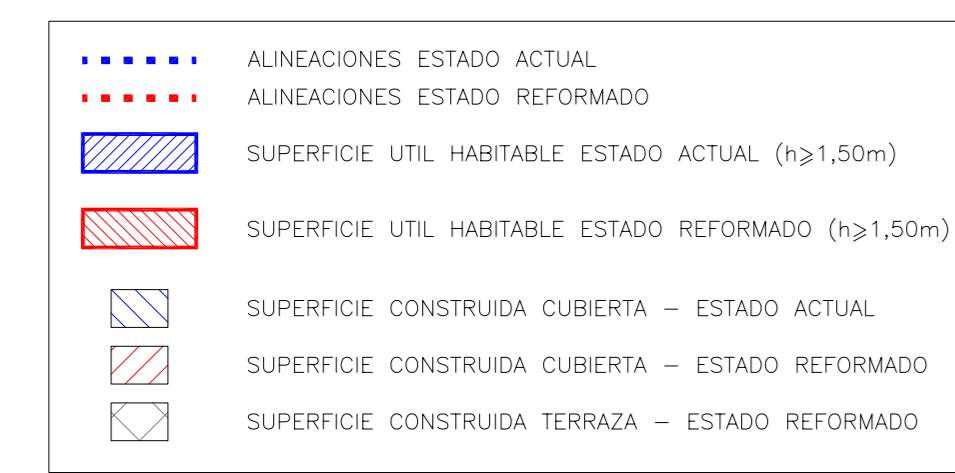

	SUPERFICIE CONSTRUIDA CUBIERTA	SUPERFICIE CONSTRUIDA TERRAZA	SUPERFICIE CONSTRUIDA TOTAL	SUPERFICIE UTIL h _{≥1,50m}
ESTADO ACTUAL	81,08m ²	-	81,08m ²	22,60m ²
ESTADO REFORMADO	43,07m ²	35,38m ²	78,45m ²	28,06m ²

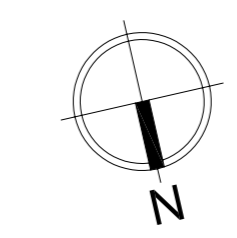

ESTUDIO DE DETALLE
REFORMA DE CUBIERTA EDIFICIO LANGAKO PLAZA 1-6 DE ZARAUTZ

PROMOTOR: COMUNIDAD DE PROPIETARIOS

REDACTOR: **B** SL
ARQUITECTOS: JOSE M^º ALKORTA AZKUE, CARMEN ALKORTA AZKUE
ARQUITECTO TECNICO: JUAN MANUEL RAMILLO PIZARRRO

PLANO: MODULO DE VIVIENDA - COMPARATIVO ESTADO ACTUAL Y ESTADO REFORMADO

ESCALA: E: 1/100
FECHA: ENERO 2013
N^º: 2

ASESORIA Y GESTION TECNICA LURBEL, S.L.